**NANO® ATLAS® TITAN® MAGNUM®
OZONE GENERATOR**

Operator's Manual



CONTACT

China Agent: Beijing Tonglin Technology Co., LTD
Phone: 010-82461830
Website: www.absoluteozone.net

TABLE OF CONTENTS

Section 1	General Information	4
1A.	Description	5
1B.	Specifications	6
1C.	Accessories	7
1C.i	Ozone Generation	7
1C.ii	Required Accessories	7
Section 2	Installation	10
2A.	Location	10
2B.	Electrical	11
2C.	Plumbing	11
2D.	Gas Connections	12
2E.	Remote Control	12
Section 3	Operation	14
3A.	LCD Control Panel Overview	14
3B.	System Startup	16
3C.	System Shutdown	17
3D.	Standard Operating Procedures	17
Section 4	Maintenance and Service	18
4A.	Preventative Maintenance	18
4B.	Troubleshooting	18
Section 5	Ozone Overview and Safety Procedures	21
5A.	General Information	21
5A.i	Relative strength of ozone	21
5A.ii	Micro-flocculation and oxidation	21
5B.	General security information	22
5B.i	Ozone Properties	22
5B.ii	Ozone Uses	22

TABLE OF CONTENTS

5C. Hazards	23
5C.i Health Hazards Detection	23
5C.ii Health Hazards Effects on Humans	23
5C.iii Electrical Hazards	24
5C.iv Fire Hazards	24
5C.v Chemical Action	24
5D. Precautions for Safe Handling and Use	25
5D.i Ozone Monitors	25
5D.ii Ventilation	25
5D.iii Emergency Procedure	25
5D.iv Respiration Protection	25
5D.v Education and Training	26
5E. System Operations and Maintenance	27
5E.i Safety Precautions and Equipment	27
5E.ii Maintenance Requirements	27
5F. Monitoring Equipment and location	27
5G. First Aid Procedures	28
5G.i General Information	28
5G.ii Inhalation	28
5G.iii Eye Contact	28
5G.iv Precautions	29
5G.v Emergency Information Form	29
Section 6 Ozone Limited Warranty	30
Section 7 Dimensions	32

IMPORTANT SAFETY INSTRUCTIONS - PLEASE READ CAREFULLY BELOW AND FOLLOW ALL INSTRUCTIONS

Read this manual completely before the operation

WARNING: High voltage is present inside the enclosure

USE EXTREME CAUTION

- Operate the generator with safe access to electrical power
- Connect to a GFCI type receptacle
- Follow all applicable electrical codes
- Do not bury chord

WARNING: To reduce the risk of electrical shock, please ensure to replace the damaged electrical chord immediately

ELECTRICAL SHOCK HAZARD: Turn OFF all the power switches and disconnect the power chord from the power source receptacle before performing any service work. Failure to do so could result in serious injury or death.

Absolute Ozone® ozone generator cell design is based on proprietary Microfluidic Platform technology, constructed from ozone-resistant materials, and offers extremely high performance and reliability. The ozone cell is designed to be absolutely maintenance and service-free. The anticipated service life is 15-20 years.

1A. Description

Absolute Ozone® are modular generators that can be assembled into systems from 15 g/h to up to 5 kg/h ozone production. Atlas 30 UHC produces 23 g/h of ozone at a concentration of up to 23% by weight or as specified in the performance test report supplied with every unit. Absolute Ozone® Ozone generators are designed to produce ozone for a variety of applications such as, but not limited to:

- Water Disinfection for Bottled Water Plants, Medical & Pharmaceutical Facilities, Swimming Pools, etc.
- Industrial Processes, Chemical production, Laboratories, Electronic Production, Mining, etc.
- Aquatic Life Support Systems for Marine Mammals, Fish Hatcheries, and Large Aquarium.
- Food Processing, Food Processing Facilities Disinfection, Food Preservation.
- Soil Remediation, Ground Water Remediation.
- Wineries Facilities Disinfection, Barrel Disinfection.
- Cooling Towers Water Treatment, Technological Processes Water Treatment.
- Potable Water Disinfection for Small Communities.
- Waste Water Treatment for Industrial Plants, Technological Production Processes, Commercial Facilities Waste Water Treatment, Dangerous Chemical and Bacteria Treatment, etc.

SECTION 1 GENERAL INFORMATION

1B. Specifications

MODEL	OZONE PROD. (G/H)	WORKING PRESS. (PSIG)	OZONE CONC. (% W/W)	POWER OPTIONS
NANO 15	15	20	5-10	120V ~10%, 50/60Hz, 2.5A 230V ~10%, 50/60Hz, 1.25A Max. Power Cons: 200W
ATLAS 30 / TITAN 30	30		9-12	
ATLAS 30C / TITAN 30C	30	20	9-16	120V ~10%, 50/60Hz, 5.5A 230V ~10%, 50/60Hz, 2.75A Max. Power Cons: 350W
ATLAS H30 / TITAN H30	20		9-22	
ATLAS 60 TITAN 60	60	25-40	5-12	120V ~10%, 50/60Hz, 6.5A 230V ~10%, 50/60Hz, 3.5A Max. Power Cons: 550 W
ATLAS 60LP TITAN 60LP	20	20	5-12	120V ~10%, 50/60Hz, 6.5A 230V ~10%, 50/60Hz, 3.5A Max. Power Cons: 550 W
ATLAS 80 TITAN 80	80	25-40	5-12	120V ~10%, 50/60Hz, 8.5A 230V ~10%, 50/60Hz, 4.25A Max. Power Cons: 650W
ATLAS 100 TITAN 100	100	30-50	5-12	120V ~10%, 50/60Hz, 10A 230V ~10%, 50/60Hz, 5A Max. Power Cons:950W
MAGNUM 120LP	120	20	6-14	230V ~10%, 50/60 Hz, 6.9A Max. Power Cons: 1600W
MAGNUM 160	160	30-50	6-12	230V ~10%, 50/60 Hz, 7.8A Max. Power Cons: 1800W
MAGNUM 200	200	30-50	6-12	230V ~10%, 50/60 Hz, 8.7A Max. Power Cons: 2000W

1C. Accessories

Absolute Ozone® ozone generators could be used with several accessories and safety devices to ensure a long service life of the ozone generator.

1C.i Ozone Generation

- **Air Compressor:** The air compressor pumps ambient pressurized air into the oxygen generator/concentrator
- **Oxygen Generator/Concentrator:** separates Oxygen from Nitrogen and supplies it directly into the ozone generating cell inside the ozone generator

1C.ii Required Equipment and Accessories

- **Oxygen Generator/Concentrator:** The oxygen generator uses a PSA (pressure swing absorption) molecular sieve bed to remove dirt, moisture, nitrogen, and other trace gases, producing oxygen at greater than 90% purity and less than -60°C dew point. The air compressor pumps ambient air into the oxygen generator input. Then, the oxygen generator outputs oxygen (O₂) feed gas into the ozone generator cell and enables the ozone generator to produce ozone effectively at 6 to 23%wt. Ozone concentration, depending on oxygen flow and generator type. In our experience, oxygen generators manufactured by AirSep work very well with AbsoluteOzone® ozone generators.
- **Oxygen Filter:** To protect the Absolute Ozone® generator from sieve particles in case of oxygen generator failure or malfunction, we recommend installing an oxygen filter after the oxygen generator and before the ozone generator

1C.ii Required Equipment and Accessories

- **Ozone Flow Control Valve (Flow Meter):** This should be installed downstream from (after) the ozone generator to maintain working pressure across the ozone cell as specified for optimal performance.
- **ALD 2000 Flood Prevention Device:** We recommend installing an ALD 2000 with every ozone system treating water to prevent water from backing up into the ozone generator and damaging it. Non-return (check valves) do not provide 100% water flooding protection to the ozone generator - **WE RECOMMEND** installing the ozone generator **WITH** the ALD 2000 or similar device when treating liquids.

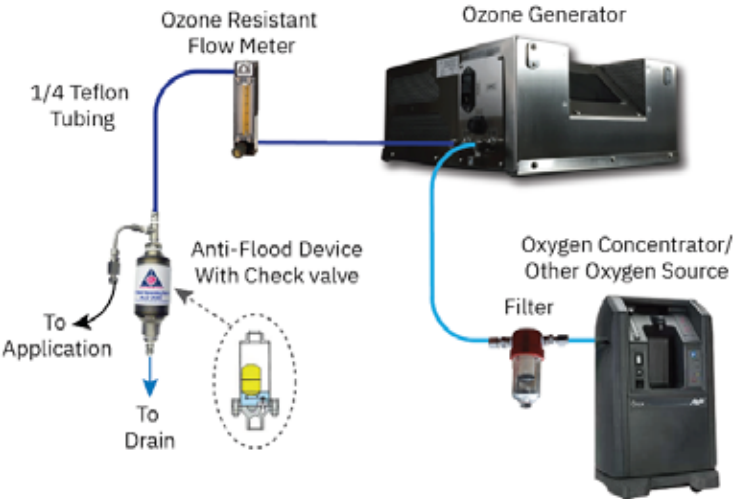

1C.ii Required Equipment and Accessories

Ozone Injector for Water Treatment Applications (Venturi):

Inlet water flows through the pump and the ozone injector, creating a vacuum that pulls ozone gas from the ozone generator and injects the ozone gas into the water flow. The injector should be sized to dissolve a minimum of 90% of the ozone gas into the water flow continuously.

Ozone Degas Tank: Ozone-enriched water from the ozone injector flows into the degas chamber/tank, where a slow down of water flow by 2 min allows any undissolved ozone and oxygen gas to rise to the top and be vented through a bleed-off valve ALD2000R to the outside or through an ozone destructor.

Ozone Destructor: Undissolved ozone gas passes through the regular or heated catalytic ozone destructor that is made up of non-consumable manganese dioxide (heat-protected from moisture fouling in heated destructor). The manganese dioxide offers redundant ozone destruct capabilities if selected and sized correctly.

2A. Location

Ozone Generator installation should allow for good access to proper electrical power and required gas connections and allow good cooling air circulation for the Ozone Generator(s).

DO NOT OBSTRUCT COOLING AIR VENTS ON THE OZONE GENERATOR.

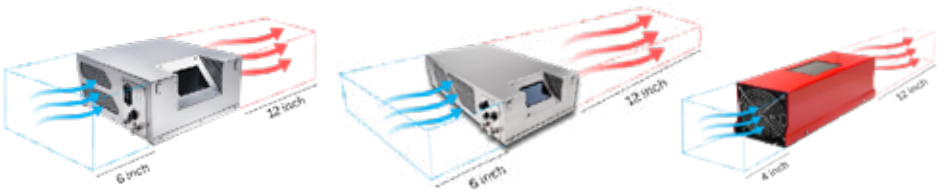

Absolute Ozone® generators should be installed in a dry, cool space shielded from weather conditions. The storage temperature ranges from -40°C to 50°C . For optimal performance, the recommended operating temperature should be maintained between 5°C to 24°C .

The ATLAS/MAGNUM® Ozone Generators have a universal mounting design to be installed on a vertical wall, on a horizontal or tilted bench, mobile cart or skied. TITAN® enclosure is designed for a 19" electronic mount rack.

Reversible Universal Control Panel



Control Panel
In Upright (For
Benchmount
Installations)
Position



Remove 4 Screws
and Reverse the
Control Panel
180 Degrees to
Downright (For Wall
Mount Installations)
Position*



Tighten Screws



Now the ATLAS/
Magnum can be
Installed in Wall
Mount
Position

*Please be careful to not disconnect LCD wires when reversing control panel

Stackable Without a Rack

ATLAS/MAGNUM® ozone generator comes equipped with attachment tabs that can be reversed to provide you with the liberty to install the generator one on top of another in a rack mount formation but without requiring a rack. When ozone generators are installed in a stack, a provision should be made for the disassembly of one of the units in the unlikely event that repairs are required.

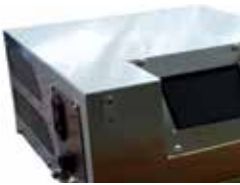

Reversible Tabs
in Original
Position



Loosen the Screws
and Swing the Tab
into the Upright
Position



Tighten Screws



Now it can be
Installed in Rack
Mount Formation

2B. Electrical

Main Power Supply Circuit: Generators are supplied with a 3-5 feet power cord. Connect the power cord to a standard grounded power source, according to a local electrical code only.

2C. Plumbing

When injecting Ozone into the water, all measures should be taken to protect the Generator Cell from water exposure/flooding, which may cause internal cell damage. An ALD2000 or similar automatic liquid drain system is recommended to be installed on the ozone line to Venturi to prevent water flooding.

2D. Gas Connections

The Ozone Generator should be connected by tubing made from material appropriate for ozone and oxygen applications. Connect the Ozone Generator according to indications on input and output bulkheads. All efforts should be made to protect the generator from exposure to incorrect operating gas pressure or excessive pressure fluctuations, which may lead to damage to electronic circuitry and the ozone cell. For applications where pressure fluctuations are possible, we strongly recommend the installation of a buffer tank with an appropriate hi-low pressure switch. It is **VERY IMPORTANT** to protect the Ozone Generator from any possible contamination from the oxygen concentrator or ozone injection side by installing appropriate filters, anti-flood, and other contamination-restricting devices upstream/downstream from the generator. Compressed air supplied to the oxygen concentrator should be free of oil vapours.

2E. Remote Control

Absolute Ozone® ozone generators are equipped with standard "On/Off" remote control terminals that can be controlled remotely by the operator, ambient ozone monitor, or PLC.

SECTION 2 INSTALLATION

2E. Remote Control

4-20mA On/Off Power Remote Control

- Remote control of ozone production level can be achieved by 4-20mA at 10 V signal. The function of this power control is not linear.
- Remote On/Off. The remote Switch must be normally open for the generator to be "On" and closed to stop the Ozone production.
- That switch has to be connected to dry contacts only (not connected to ground or connected to any voltage source AC or DC)
- Remote Ozone Generator status indicator.
 - a) During Normal Ozone generator operation. Pins 5 and 6 are normally open, pins 6 and 7 are normally closed.
 - b) If Remote Control Switch is Off or safety shutoff is activated the circuit between pins 5 & 6 will be closed and 6 & 7 open.

Standard Remote Control Schematic

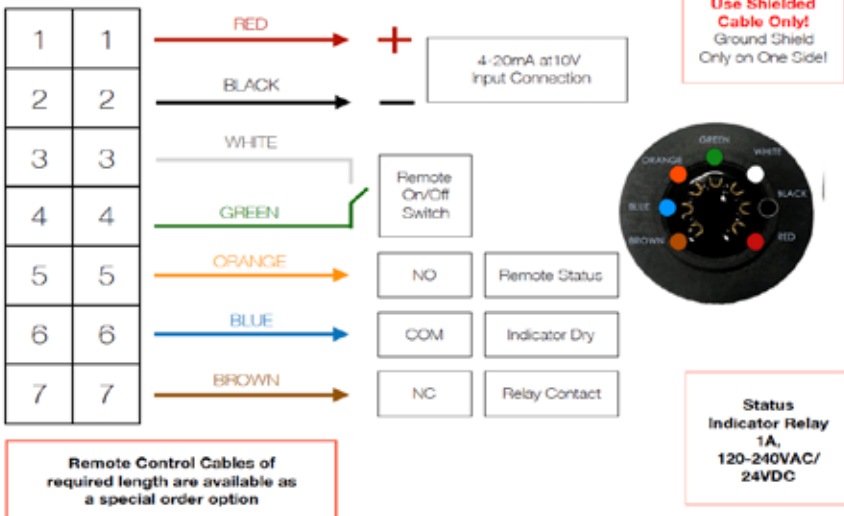

3A. LCD Control Panel Overview

Here is a general description of the controller and the features it offers:

All Absolute Ozone® generators come with 4-20mA 10 V remote power level control as a standard feature that allows adjusting power going to the ozone cell remotely to a required level that is later automatically maintained by a control system, regardless of minor voltage or pressure deviations.

Internal iOzone™ intelligent diagnostic/controller system protects Absolute Ozone® generators from the following potential problems:

- Incorrect wiring or voltage applied to the remote control terminals.
- Incorrect power applied in the specified range (too low, too high)
- Incorrect operating pressure.
- Ozone cell contamination by water or similar.
- Bad feed gas quality (too much humidity or contamination)
- Overheating or failure of the cooling system, etc.

Power saving Mode: After a few minutes of inactivity, the LCD screen switches to a power-saving mode and shuts off to conserve energy. (This does not affect the generator's performance). If you want to leave the power-saving mode, you can touch the screen at any point to turn ON the LCD.

SECTION 3 OPERATION



Photos of typical LCD control touch screen.

The LCD screen shows the following parameters:

- Selected or Expected power setting %, so you will be able to see on the screen power selected by the remote control or slider.
- Actual power % & Watt going to an ozone cell.
- The cell voltage V.
- Current Amp going to the ozone cell
- The gas pressure inside the ozone cell.
- The temperature inside the ozone cell.
- The LCD screen will allow by touch to switch the generator on and off and to adjust the desired power by moving the slider on the screen with your finger.
- Indication of power setting signal (LCD/RC - remote control).

- In the event that incorrect operating parameters are applied to the ozone generator the unit is switched off by the Ozone intelligent diagnostic control system, and the LCD screen will indicate which of the parameters caused the generator shutdown.
- In a safety shutdown mode the generator will be constantly monitoring operating parameters and the moment they are corrected the generator will restart automatically, without any assistance.
- I.e. if there is a power spike or if there is a pressure drop caused by temporary power failure and interruption of oxygen supply, the moment the pressure or supplied voltage is restored to normal, the generator will restart and will produce ozone again.

3B. System Startup

1. Make sure the Ozone Generator enclosure is securely attached to an appropriate frame or wall Ozone Generators Stack.
2. Make sure all connections to the generator, power, and gas are made according to local codes and regulations.
3. Purge the generator with 90% or higher concentration of oxygen and ensure a free flow of oxygen through the system and removal of contaminants. Conduct system leak test applying working pressure +/-10% using oxygen only. Adjust gas pressure across the cell according to specifications using a downstream Control Valve (on the flow meter) and pressure gauge (supplied by the installer).
4. Plug the system into a specified receptacle.
5. Flip the Power Switch into the "ON" position.
6. Slide the red dot on the power control slider upwards to adjust to desired power from 0-100% according to supplied "Ozone Generator Performance Test" chart. Now the generator is at optimum production mode, and ozone should be flowing through the system.

3C. System Shutdown

1. Slide the red dot on the power control slider downwards to adjust power from 0%. (No ozone is produced at this time.)
2. Switch the power switch to the OFF position.
3. Unplug the system from the power source if required.
4. Close down the downstream Control Valve (located on the flow meter -supplied by the installer) to protect the unit from accidental flooding.
5. Turn the oxygen source off.

3D. Standard Operating Procedures

NOTE: To ensure a long trouble-free service life for the ozone Generator, provide the following operating conditions:

- Make sure that the oxygen concentrator is maintained properly and is producing oxygen at greater than 90% purity and less than -60°C dew point. Check sieve conditions and replace it as often as recommended by the manufacturer.
- Install an oxygen filter and oxygen dryer between the oxygen concentrator and the Ozone Generator, check the condition and replace the cartridge to protect Ozone Generator from sieve particles in case of oxygen generator failure and moisture.
- Make sure to maintain working pressure across ozone cells as specified for the generator protection and most efficient production.
- When injecting ozone into water, make sure to protect the generator from flooding by installing a device capable of preventing water backup. Check valves usually start leaking after a few days of operation in ozone and cause serious damage to the ozone cell. We recommend using devices which could automatically drain water out of the ozone line and stop it from entering the ozone cell.

4A Preventative Maintenance

Generally, Absolute Ozone® is maintenance-free, although it is useful to check the Ozone Generator for proper operation:

1. Make sure there are no warnings on the LCD screen.
2. Inspect all gas, power and signal cables and connectors visually
3. Make sure that all air vents are not obstructed.

Monthly:

1. Make sure that all system equipment (oxygen concentrator, air compressor, etc.) is maintained according to the manufacturer.
2. Remove and replace or clean filter cartridges and other devices if installed and required.
3. Perform general cleaning of the cabinet exterior after disconnecting the equipment from the electrical source.
4. Using clean/dry compressed air or a vacuum cleaner, blow out the interior or vacuum the cabinet, taking special care around electronic components and wiring.

4B. Troubleshooting

Knowledge of electrical applications is required for troubleshooting. Contact a certified electrician if you are unsure of your ability to service the equipment. If any problem persists, please call (+1)780-486-3761. We will have one of our system engineers discuss your situation with you over the phone.

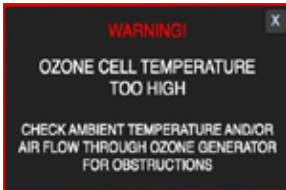
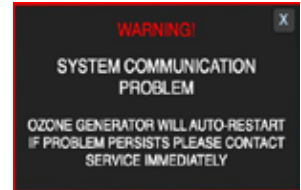
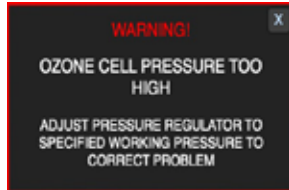
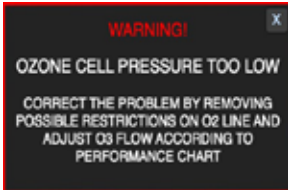
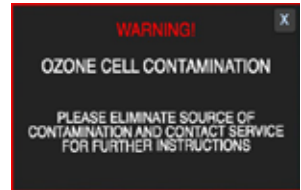
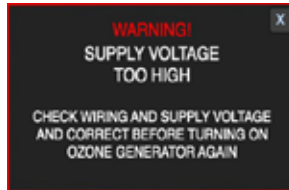

Symptom (Warning Message):

- **INCORRECT REMOTE CONTROL VOLTAGE**

Please make sure the voltage you have supplied to the remote control (4-20 MA signal) is not higher than 10V.

- **OZONE CELL CONTAMINATION.**

The ozone sensor detected ozone cell contamination by water or possibly some other conductive liquids. Please switch the ozone generator off, locate and eliminate the source of the contamination. While having power off, run oxygen through the ozone cell for several days to dry the liquid and/or other contaminants out and then try to restart the ozone generator.

- **SYSTEM COMMUNICATION PROBLEM** If, after several attempts, it does not restart, please contact us for technical support.

- **OZONE CELL PRESSURE TOO LOW**

Please make sure there are no restrictions on the oxygen line coming to the ozone generator and that the flow is only adjusted on the ozone line after the ozone generator to maintain the correct working pressure, if the pressure is too low due to an incorrectly set pressure regulator or failure of oxygen generators, please rectify the problem and the ozone generator will continue operation.

- **OZONE CELL PRESSURE TOO HIGH**

Please adjust the oxygen pressure regulator to the specified pressure and that will rectify this problem and warning message.

- **OZONE CELL TEMPERATURE TO HIGH**

Make sure that the ambient temperature in the installation room is below 25 c, and check that there is good unrestricted cooling airflow through the ozone generator (not obstructed on either side of the cooling grills). Please make sure that the cooling fan is working properly. in case of the cooling fan failure, please contact technical support for further instructions

- **SUPPLY VOLTAGE TOO HIGH OR TOO LOW**

Please make sure that the voltage supplied to the ozone generator is as specified +/- 5% in order to correct the problem. If the voltage supplied is as specified and the problem persists, please contact our service department

5.A General Information

5A.i Relative Strength of Ozone

The following compares the strengths of several common oxidizing reagents (EOP vs. Cl₂)

- Elemental Fluorine (2.25)
- Hydroxyl Radical (2.05)
- Ozone (1.52)
- Hydrogen Peroxide (1.30)
- Hypochlorite (1.10)
- Chlorine (1.00)
- Chlorine Dioxide (0.93)
- Bromine (0.57)

5A.ii Micro-Flocculation and Oxidation

Ozone oxidizes the following metals (known as micro-flocculation), enabling their removal via filtration:

- Iron
- Copper
- Manganese
- Zinc
- Arsenic

Ozone neutralizes “nuisance” compounds - most commonly, hydrogen sulfide.

5.B General Safety Information

5B. i Ozone Properties

- Colorless to blue gas (greater than -169 F).
- The characteristic odor is often associated with electrical sparks or lightning in concentrations of less than 0.02 ppm.
- Highly chemically reactive.
- Non-flammable, non-carcinogenic.
- Hazardous polymerization can occur in some rare materials.
- Spontaneously decomposes to oxygen gas.

5B. ii Ozone Uses

- Air and water disinfection
- Surface sanitation
- Water treatment plants
- Bottled water, irrigation, community water supplies, swimming pools/spas, etc.
- Aquariums/life support
- Agricultural wash water
- Wastewater treatment
- Mold and bacteria control in cold storage

5.C Hazards

5C.i Health Hazards Detection

Gaseous ozone can be detected in the air by its distinctive odor at concentrations of about 0.02 ppm. Although each nose varies, olfactory fatigue occurs quickly. Initial small exposure may reduce cell sensitivity and/or increase mucous thickness, producing resistance to low gaseous ozone levels.

DO NOT RELY ON ODOR AS A WARNING OF HIGH OZONE CONCENTRATIONS.

The Permissible Exposure Level (PEL) or time-weighted concentration for gaseous ozone to which workers may be exposed is 0.1 ppm averaged over 8 hours, 5 days a week (OSHA). The short-term exposure limit is 0.3 ppm averaged over 15 minutes. The concentration of 5.0 ppm ozone in the air is generally accepted as Immediately Dangerous to Life or Health (IDLH).

5C.ii Health Hazards Effect on Humans

Gaseous ozone acts as a primary irritant, affecting mainly the eyes, upper respiratory tract, and lungs. Inhalation produces various degrees of respiratory effects, from irritation to pulmonary edema (fluid in the lungs). Short exposure to 1-2 ppm concentrations causes headaches as well as irritation to the respiratory system but, symptoms subside when exposure ends. High concentrations of ozone produce severe irritation to the eyes and respiratory system. Exposure above the ACGIH/OSHA limits may produce nausea, chest pain, coughing, fatigue, reduced visual acuity, and pulmonary edema. Symptoms of edema from excessive exposure can be delayed one or more hours. There is no threshold limit, and so no exposure (regardless of how small) is theoretically without effect from ozone's strong oxidative ability.

5C.iii Electrical Hazards

Turn OFF all power switches and disconnect the power cord from the power source receptacle before performing service work. Failure to do so could result in serious injury or death. Operate the generator with safe access to electrical power. Connect the generator to a G.F.C.I. type receptacle or as required by local electrical codes & regulations. Do not bury the electrical cord. To reduce the risk of electrical shock, replace the damaged cord immediately.

5C.iv Fire Hazards

Ozone is non-flammable. The decomposition of ozone into oxygen gas (O_2) can increase the strength of fire. Ozone is unstable at room temperature and spontaneously decomposes to oxygen gas. Avoid ignition sources such as heat, sparks, and open flame. Keep away from strong combustible materials such as grease, oils, and fats.

5C. v Chemical Accion

Ozone is chemically incompatible with all oxidizable materials, both organic and inorganic.

5.D Precautions for safe Handling and Use

5D.i Ozone Monitors

Ambient ozone monitoring/control equipment (available from Absolute Ozone®) should be installed in the areas where ozone is being generated or applied. In a case when ambient ozone concentration reaches or becomes higher than 0.05 ppm, the ozone monitor/controller should switch the power of the ozone generator off and produce a warning audio/visible signal to allow people to clear the room and avoid high concentration ozone exposure.

5D.ii Ventilation

It is mandatory that general and local exhaust ventilation be provided to dilute and disperse small amounts of ozone into the outside atmosphere. Federal, state, and local regulations must be followed.

5D.iii Emergency Procedure

Due to the short life of ozone, evacuation and ventilation are all that are generally required in the event of a high ambient ozone alarm. All ozone-generating and delivery equipment should be shut down (manually or automatically by alarm), and a high-speed fan activated to dilute and disperse ozone into the atmosphere. Personnel should leave the affected area until levels are returned to below 0.1 ppm.

5D.iv Respiratory Protection

A disposable respirator (3M #N95 8214/8514 - Minneapolis, MN, www.3m.com) is recommended for relief against ozone levels up to 10 times the OSHA PEL or applicable government occupational exposure limits, whichever is lower.

5D.v Education and Training

The education and training of workers are the responsibility of the end user. An effective training program must be practical, based on written work procedures, and specific to both the job site and the tasks to be performed. Training shall also include the responsibilities and responses of workers in an emergency. The employer shall ensure through the education and training program that all workers can work without risk to themselves or others around them. All workers must clearly understand their responsibilities concerning not only specific work procedures but also the need to report all hazards, accidents, or incidents and injuries. Management and employees shall review all routine work and emergency procedures jointly at least once annually.

TOXIC EFFECTS OF GASEOUS OZONE

OZONE CONCENTRATION	EFFECT
0.01 - 0.10 (PPM)	Range of Odor Threshold. Headaches, irritation to respiratory tract, severe irritation to eyes
0.1 (PPM)	Permissible concentration (8 h work day)*
0.3 (PPM)	Permitted short-term exposure (15min.)*
1.0-10.0 (PPM)	Nausea, chest pain, coughing, fatigue, reduced visual acuity, pulmonary edema
5.0 (PPM)	Immediately Dangerous to Life or Health (I.D.L.H.)*
>20.0 (PPM)	Can be fatal after 1 hour
>50.0 (PPM)	Can be fatal after 30 minutes

*regulations regarding levels may vary from country to country."

5.E Systems Operations and Maintenance

5E.i Safety Precautions and Equipment

Repair and maintenance of the ozone system shall be done under the direction of qualified personnel. Qualification shall consist of instruction from the equipment supplier on the safeguards and procedures necessary for the safe performance of the work. Repair of the Ozone Generator could be performed only under the supervision of Absolute Ozone® engineers unless authorized and instructed otherwise by Absolute Ozone personnel. All equipment in an ozone plant (ozone generator, piping, pumps, tanks, etc.) coming in contact with gases containing ozone must be maintained free of oil and grease. Monitoring equipment and alarm system shall be tested and serviced according to the manufacturer's instructions. The planned maintenance of all safety equipment is essential to worker safety.

5E. ii Maintenance Requirements

It is the joint responsibility of the manufacturer, supplier, and installer of the Ozone generating and handling equipment to determine whether or not the system is working properly. The operation and maintenance manual provided with the equipment outlines the operating procedures and maintenance requirements.

5F Monitoring Equipment and location

Ambient ozone detection monitors shall be located to monitor ozone room air and production/plant room air for indoor applications. Proper Ozone Monitoring equipment should be used to protect personnel from dangerous levels of ozone exposure. Absolute Ozone® could provide suitable ozone monitoring at customer request.

5G. First Aid Procedure

5G. i General Information

1. DO NOT PANIC. If exposure to gaseous ozone causes headaches or shortness of breath, immediately remove the worker to a fresh-air environment.
2. Ensure there is no more danger to yourself or the worker.
3. Workers who have been exposed to low concentrations of ozone should be given oxygen to breathe while under the observation of trained personnel.
4. If exposure is severe, send for medical assistance immediately.

5G. ii Inhalation

1. Assess the worker's breathing.
2. All unconscious workers must be placed in the drainage position (on their sides); so that fluids can drain from the airways once breathing has been restored.
3. Check pulse.
4. If breathing has ceased, start artificial respiration (rescue breathing is the most effective method) until breathing has been restored.
5. Send for medical assistance immediately.
6. If absent, begin cardiopulmonary resuscitation (CPR).

5G. iii Eye Contact

1. Effective irrigation should start immediately. Eyes should be irritated for 30 minutes by the clock with running tap water or preferably normal saline.
2. Effective irrigation must be continued while en route to the hospital.

5G. iv Precautions

Workers with a previous cardiopulmonary (heart and lung) condition must consult their physician before working in an area in which they may be exposed to ozone. Significant alterations in cardiopulmonary functions have been documented when such workers have been exposed to low concentrations of ozone.

5G. v Emergency Information Form

An emergency information form (see example below) should be filled out before operating the Ozone Generator.

EMERGENCY INFORMATION	
FILL IN ALL INFORMATION NOW; IF YOU DO NOT KNOW, FIND OUT BEFORE AN EMERGENCY OCCURS.	
Person responsible for control/evacuation:	_____
Phone #:	_____
Alternate:	_____
Phone#:	_____
Emergency response team:	_____
Phone #:	_____
Fire Department:	_____
Phone#:	_____
Doctor/First Aid:	_____
Phone #:	_____
Hospital:	_____
Phone#:	_____
Ozone Manufacturer:	_____
Phone #:	_____
Ozone Leak Location:	_____
Locations to notify in emergency situations:	
Name:	Phone:
_____	_____
_____	_____
_____	_____
_____	_____
_____	_____
_____	_____
_____	_____
_____	_____
_____	_____
_____	_____

Absolute Ozone® Five Years Limited Warranty

The limited warranty set forth below applies to products manufactured by Absolute Ozone® 10712 - 181 Street, Edmonton, AB., T5S 1K8, Canada, and sold by Absolute Ozone® and its authorized dealers. This limited warranty is given only to the first retail purchaser of such products and is not transferable to any subsequent owners or purchasers of such products.

Absolute Ozone® warrants that Absolute Ozone® will repair or replace, at Absolute Ozone's option, any part of such products proven to be defective in materials or workmanship within five (5) years from the date of original purchase. Parts are covered under the five (5) year warranty when and only when required operating conditions and procedures as described in this manual are performed and provided. This warranty specifically excludes any components not manufactured by Absolute Ozone® that are external to the products covered, such as pumps, air compressors, monitors, tanks, or related components.

Absolute Ozone® will assist with warranty claims for such components purchased through Absolute Ozone®; limited to the extent of the manufacturer's standard warranty.

ANY REPAIR OR REPLACEMENT WILL BE WARRANTED ONLY FOR THE BALANCE OF THE ORIGINAL FIVE (5) YEAR WARRANTY PERIOD. THIS LIMITED WARRANTY DOES NOT INCLUDE ANY OF THE FOLLOWING:

- (a) Any labor charges for troubleshooting, removal, or installation of such parts;
- (b) Any repair or replacement of such parts necessitated by faulty installation, improper operating procedures and conditions, misuse, abuse, negligence, accident, fire, flood, repair materials, and/or unauthorized accessories;
- (c) Any such products installed without regard to required local codes and accepted trade practices;
- (d) Damage caused by water passing through the unit;
- (e) Damage caused by operating below or above specified working pressure;
- (f) **ANY IMPLIED WARRANTY OF MERCHANTABILITY OR IMPLIED WARRANTY OF FITNESS FOR PARTICULAR PURPOSE, AND SUCH WARRANTIES ARE HEREBY DISCLAIMED; AND**
- (g) **ABSOLUTE OZONE® SHALL NOT BE LIABLE UNDER ANY CIRCUMSTANCES FOR LOSS OF USE OF SUCH PRODUCTS, LOST PROFITS, DIRECT DAMAGES, INDIRECT DAMAGES, CONSEQUENTIAL DAMAGES AND/OR INCIDENTAL DAMAGES.**

SECTION 6 WARRANTY

NOTE: ANY WORK PERFORMED ON ABSOLUTE OZONE PRODUCTS WITHOUT PRIOR AUTHORIZATION FROM ABSOLUTE OZONE WILL AUTOMATICALLY VOID THIS WARRANTY. ANY ABSOLUTE OZONE PRODUCT MUST BE RETURNED TO ABSOLUTE OZONE PREPAID, FOR WARRANTY EVALUATION.

THE OZONE CELL CONTAINS TAMPER-PROOF DEVICES. ANY ATTEMPT TO OPEN THE CELL WILL NOT ONLY VOID THE WARRANTY BUT WILL VOID THE POSSIBILITY OF OBTAINING ANY SERVICE BY ABSOLUTE OZONE.

TO OBTAIN WARRANTY SERVICE:

Please provide the following information:

1. Project, contact name, mailing address, and telephone
2. Installer/Mechanical Contractor
3. Serial # and date of purchase
4. The date of failure
5. A description of the failure
6. All shipping documents should clearly state **“Warranty Repair”** and **indicated the RMA number**. Absolute Ozone is not responsible for double taxes or duties resulting from improper shipping documentation.

Absolute Ozone
10712 – 181 Street,
Edmonton, Alberta,
T5S 1K8, Canada

SECTION 7 DIMENSIONS

NANO®

Weight: 10 lbs.

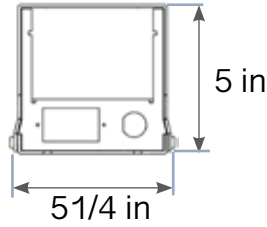
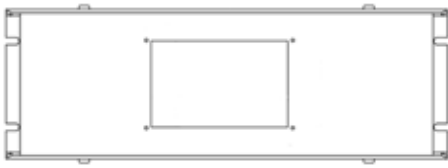

15.5 in

ATLAS®

Weight: 26 - 35 lbs.

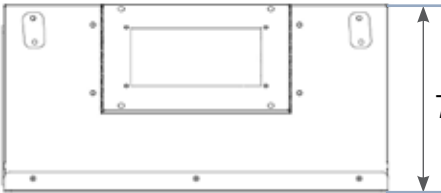

7 in

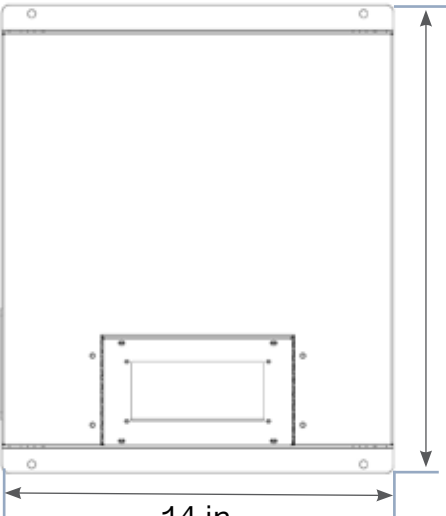
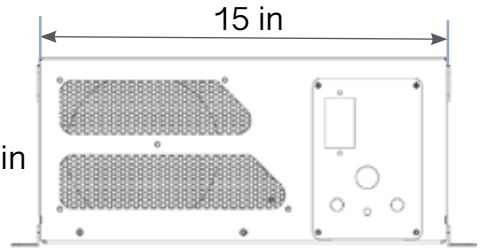

17 in

14 in

SECTION 7 DIMENSIONS

TITAN®

Weight: 26 - 32 lbs.

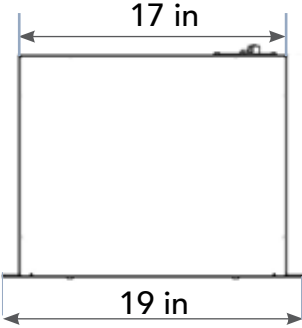
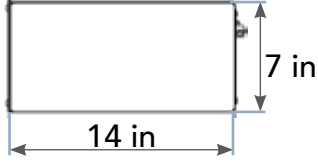
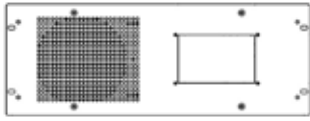

MAGNUM®

Weight: 70 lbs.

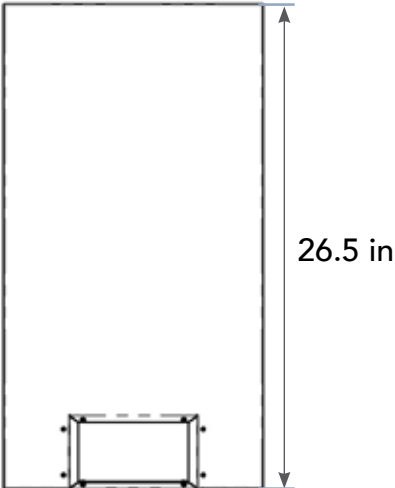
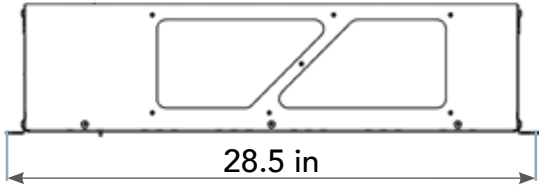
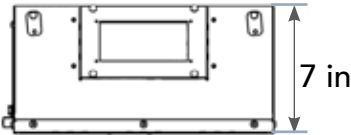

IMPORTANT:

If authorized by Absolute Ozone to remove MAGNUM enclosure cover, please ensure the screws are fastened in the same pattern in the same position as originally assembled/ found. Moreover, **ONLY USE** the same short screw as supplied on the middle threaded hole on the right side of the MAGNUM ozone generator. Using an incorrect screw or a longer length (than supplied) screw, you risk puncturing the internal ozone gas which runs directly behind the threaded hole which could potentially cause a leak and would not be covered under warranty.

SECTION 7 DIMENSIONS

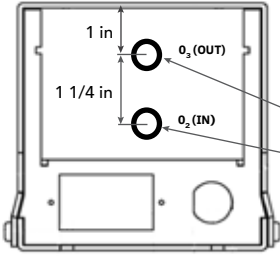

NANO[®]

Ø1/4 SS316 Compression Swagelok Type Connector

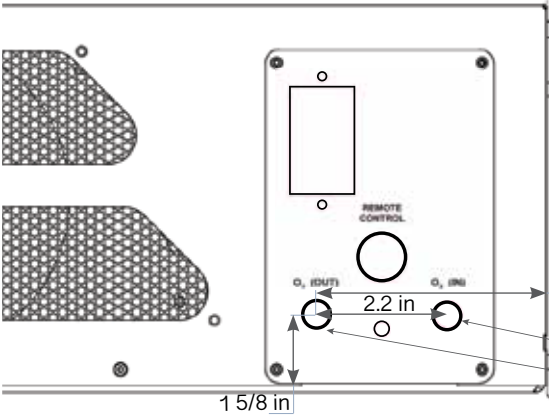

ATLAS[®]

Ø1/4 SS316 Compression Swagelok Type Connector

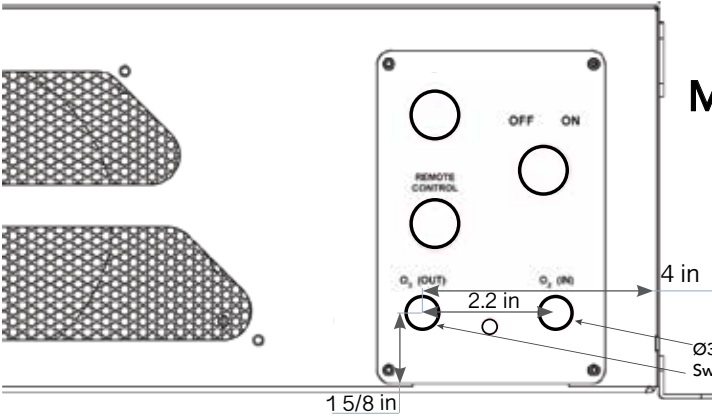

MAGNUM[®]

Ø3/8 SS316 Compression Swagelok Type Connector

SECTION 7 DIMENSIONS

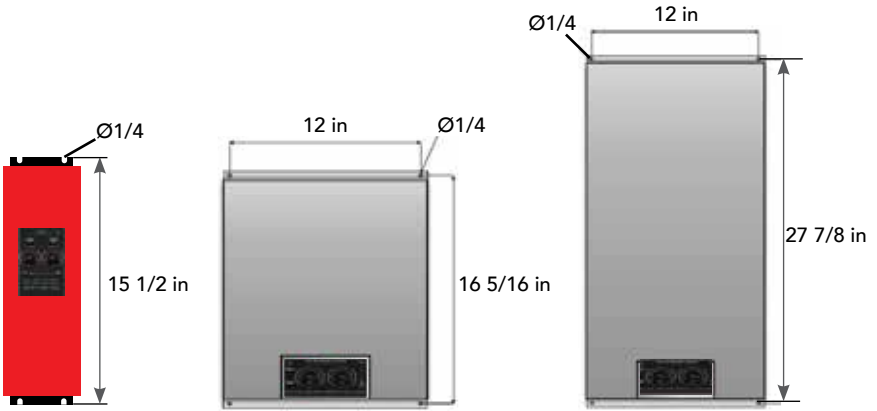

GET IN TOUCH

Our assistance to our clients over the past two decades not only provided them with the most reliable and effective working ozone systems but provided tremendous savings on operating expenses to them, as Absolute Ozone generators do not require any service repairs or maintenance first 20 years of use when installed and used correctly.

CALL US TODAY, AND LET'S DISCUSS YOUR UPCOMING OR CURRENT PROJECT